



INSTALLATION AND OPERATING INSTRUCTIONS

Tool changer

FWR

DDOC02329

THE KNOW-HOW FACTORY

Content

1	Supporting documents	3
1.1	Notices and graphics in the installation and operating instructions	3
2	Safety notices	4
3	Proper use	5
4	Personnel qualification	5
4.1	Electricians	5
4.2	Specialists	5
4.3	Instructed personnel.....	5
4.4	Service personnel.....	5
4.5	Additional qualifications	5
5	Product description	6
5.1	Type plate	6
6	Functional description	7
6.1	Functional safety	7
7	Technical data	7
8	Accessories/scope of delivery	8
9	Transportation/storage/preservation	8
10	Installation	8
10.1	Installing the storage station	9
10.2	Installing the stationary part on the robot.....	9
10.3	Installing the tool to the loose part	10
10.4	Coupling the stationary part and loose part.....	11
10.5	Installing the energy supply	12
10.6	Installing the energy elements.....	12
10.7	Installing the sensors.....	13
10.7.1	Installing the sensor on the stationary part	13
10.7.2	Installing the sensor on the storage station.....	13
11	Commissioning	14
11.1	Setting up the storage station for the first time	14
11.2	Setting the sensors in the storage station	14
12	Maintenance	15
13	Decommissioning/disposal	15
14	REACH declaration.....	16
15	Declaration of Incorporation	17

1 Supporting documents

NOTICE



Read through the installation and operating instructions before installing or working with the product.

The installation and operating instructions contain important notes for your personal safety. They must be read and understood by all persons who work with or handle the product during any phase of the product lifetime.



The documents listed below are available for download on our website www.zimmer-group.com.

- Installation and operating instructions
 - Catalogs, drawings, CAD data, performance data
 - Information on accessories
 - Technical data sheets
 - General Terms and Conditions, including warranty information.
- ⇒ Only those documents currently available on the website are valid.

In these installation and operating instructions, "product" refers to the product designation on the title page!

1.1 Notices and graphics in the installation and operating instructions

DANGER



This notice warns of an imminent danger to the life and health of people. Ignoring these notices can lead to serious injury or even death.

- ▶ You absolutely must comply with the described measures for avoiding these dangers!
- ⇒ The warning symbols are assigned according to the type of danger.

WARNING



This notice warns of a situation that is potentially hazardous to personal health. Ignoring these notices can cause serious injury or damage to health.

- ▶ You absolutely must comply with the described measures for avoiding these dangers!
- ⇒ The warning symbols are assigned according to the type of danger.

CAUTION



This notice warns of a situation that is potentially hazardous to persons. Ignoring these notices can cause minor, reversible injuries.

- ▶ You absolutely must comply with the described measures for avoiding these dangers!
- ⇒ The warning symbols are assigned according to the type of danger.

NOTICE



This notice warns of possible material and environmental damage. Ignoring these notices can result in damage to the product or the environment.

- ▶ You absolutely must comply with the described measures for avoiding these dangers!
- ⇒ The warning symbols are assigned according to the type of danger.

INFORMATION



This category contains useful tips for handling the product efficiently. Failure to observe these tips will not result in damage to the product. This information does not include any information relevant to health or workplace safety.

2 Safety notices

CAUTION



Risk of injury and material damage in case of non-compliance

The product is state-of-the-art.

The following are examples of situations in which the product may cause a hazard:

- The product is not properly installed, used or maintained.
- The product is not used for its designated purpose.
- The locally applicable regulations, laws, directives or guidelines are not observed.
- ▶ The product may only be used in accordance with these installation and operating instructions and the product's technical data. Any changes or additions to the intended use of the product, as well as modifications to the product, such as those in the following examples, require the written permission of the manufacturer:
 - Use of the product under extreme conditions, such as aggressive fluids or abrasive dusts
 - Additional drilled holes or threads
- ⇒ Zimmer GmbH shall accept no liability for any damage caused by improper use. The operator bears sole responsibility.
- ▶ Make sure that the power supply is disconnected before you mount, adjust, modify, maintain or repair the product.
- ▶ Whenever work is carried out on the product, make sure that the product cannot be actuated by mistake.
- ▶ Perform maintenance tasks, renovation work or attachment work outside of the machine's danger zone when possible.
- ▶ Do not reach into the operational range of the product.
- ▶ Always adhere to the required maintenance intervals.
- ▶ When using the product under extreme conditions, adjust the maintenance interval according to the degree of contamination.
- ▶ Check the completeness and tightening torques of all mounting screws.

3 Proper use

NOTICE



Material damage and malfunction in case of non-compliance

The product is only to be used in its original state with its original accessories, with no unauthorized changes and within the stipulated parameter limits and operating conditions.

Any other or secondary use is deemed improper.

- ▶ Operate the product only in compliance with the associated installation and operating instructions.
- ▶ Operate the product only when it is in a technical condition that corresponds to the guaranteed parameters and operating conditions.
- ⇒ Zimmer GmbH shall accept no liability for any damage caused by improper use. The operator bears sole responsibility.

- The product is intended for industrial use.
- The product is designated for use in closed facilities.
- Direct contact with perishable goods/food is not permitted.

4 Personnel qualification

WARNING



Inadequate qualification can cause injury and material damage

If inadequately qualified personnel perform work on the product, this can cause serious injuries and significant material damage.

- ▶ All work on the product must be performed by qualified personnel.
- ▶ Before working with the product, read the document in its entirety and make sure that you have understood everything.
- ▶ Observe country-specific accident prevention regulations and the general safety notices.

The following qualifications are a prerequisite for performing various work on the product.

4.1 Electricians

Electricians are able to perform work on electrical systems, can recognize and avoid possible dangers and know the relevant standards and provisions due to their technical training, knowledge and experience.

4.2 Specialists

Specialists are able to perform the assigned work, can recognize and avoid possible dangers and know the relevant standards and provisions due to their technical training, knowledge and experience.

4.3 Instructed personnel

Instructed personnel have been trained by the operating company on the tasks and possible dangers of improper behavior.

4.4 Service personnel

Service personnel are able to perform the assigned work and can recognize and avoid possible dangers due to their technical training, knowledge and experience.

4.5 Additional qualifications

Persons who work with the product must be familiar with the valid safety regulations and laws as well as the standards, guidelines and laws listed in this document.

Personnel who work with the product must have facility-issued authorization to commission, program, configure, operate, maintain and also decommission this product.

5 Product description

The product is a safe quick-change system.

It consists of a stationary part and a loose part.

The stationary part can be coupled to different loose parts.

A storage station is available as an option.

Several storage stations can be used to hold differently equipped loose parts for operation with the same stationary part.

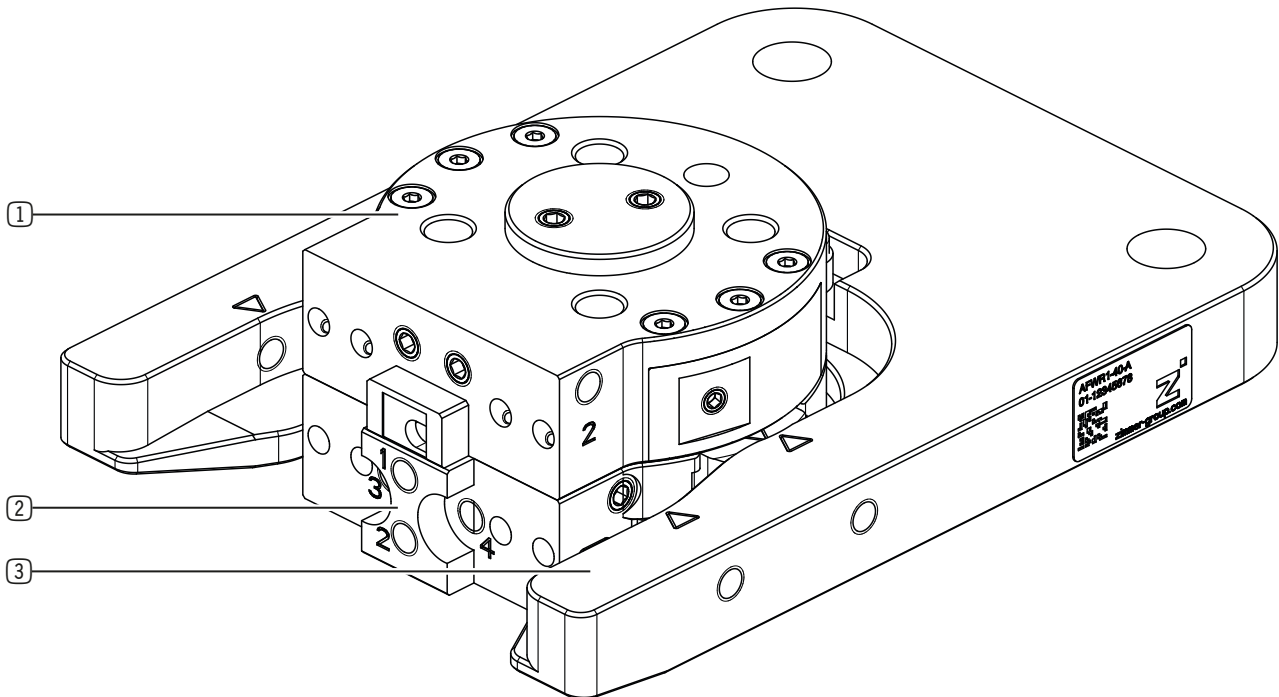

- ① Stationary part (FWRxxF)
- ② Loose part (FWRxxL)
- ③ Storage station

5.1 Type plate

A type plate is attached to the product.

The article number and the confirmation number are shown on the type plate.

- ① Article number
- ② Confirmation number

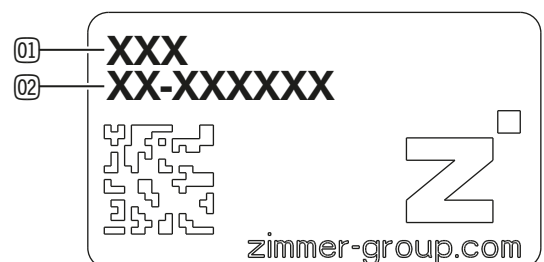

6 Functional description

The stationary part is installed on a robot. It is used to hold a loose part.

The loose part automatically locks with the stationary part during automatic extending out of the storage station.

It locks automatically when it is retracted into the storage station.

As an alternative, the loose part can be manually locked with and released from the stationary part.

6.1 Functional safety

For the overall safety of the function, all three components (stationary part, loose part and storage station) must be taken into account.

The safety function that ensures secure locking between the stationary and loose part of the product is implemented via two redundant action channels that consist of a mechanical locking and springs.

Technical supplementary safety measures (sensors) provide a high degree of diagnostic coverage. The product can thus be classified into control category 3 in accordance with Chapter 6.2.6 of DIN EN ISO 13849-1. According to Figure 5, Chapter 4.5.4 of the specified standard, the PL d can be achieved with this product.

Fault elimination in accordance with DIN EN ISO 13849-2, Annex A, Table A2 and A3 for the helical compression springs used can be given.

7 Technical data

INFORMATION



▶ You can find the information in the technical data sheet on our website.

This data varies within the series, depending on the specific design.

▶ Please contact Customer Service if you have any questions.

For the maximum tool weight, refer to the tightening torque specified in the technical data, taking into account the distance to the center of gravity and the mating force of the energy elements.

- **Tool weight:** Mass of the tool that is installed to the product and that can be retrieved from the storage station.
- **Handling weight:** Additional mass of the workpiece required for handling.

8 Accessories/scope of delivery

INFORMATION



If any accessories not sold or authorized by Zimmer GmbH are used, the function of the product cannot be guaranteed. Zimmer GmbH accessories are specifically tailored to the individual products.

- ▶ For optional accessories and those included in the scope of delivery, refer to our website.

9 Transportation/storage/preservation

- ▶ Transport and storage of the product must be done only with the original packaging.
- ▶ If the product has already been installed on the superordinate machine unit, care must be taken during transport to ensure that no unexpected movements can occur.
 - ▶ Before commissioning the product and after transport, check all power and communication connections as well as all mechanical connections.
- ▶ If the product is stored for an extended period, the following points are to be observed:
 - ▶ Keep the storage location as dust-free and dry as possible.
 - ▶ Avoid temperature fluctuations.
 - ▶ Avoid wind/drafts/water condensation formation.
 - ▶ Pack the product and do not expose it to direct sunlight during storage.
- ▶ Clean all components. There must be no soiling left on the components.
- ▶ Visually inspect all components.
- ▶ Remove all foreign substances.
- ▶ Properly remove potential corrosion spots.
- ▶ Close off unused connections using pressure-resistant closures.

10 Installation

WARNING



Risk of injury due to uncontrolled movements

Risk of injury in case of unexpected movement of the machine or system into which the product is to be installed.

- ▶ Switch off the energy supply of the machine before any work.
- ▶ Secure the power supply against being switched on unintentionally.
- ▶ Check the machine for any residual energy that may be present.

INFORMATION



Further installation information:

- The mounting screws are not included in the scope of delivery.

Assembly requirements

Permissible flatness tolerance [mm]	0,03
Strength class of the mounting screws	8.8

- ▶ Install the product on an appropriate mounting surface in accordance with the flatness specifications.
- ▶ Make sure that the mounting piece is sufficiently rigid.
- ▶ Ensure the cleanliness of the connection surfaces.
- ▶ Please note the permitted tightening torques of the mounting screws at www.zimmer-group.com/en/td.

10.1 Installing the storage station

- ▶ Insert straight pins into the fits of the storage station.
- ▶ Position the storage station on the mounting piece.
- ▶ Fasten the storage station using the mounting screws.

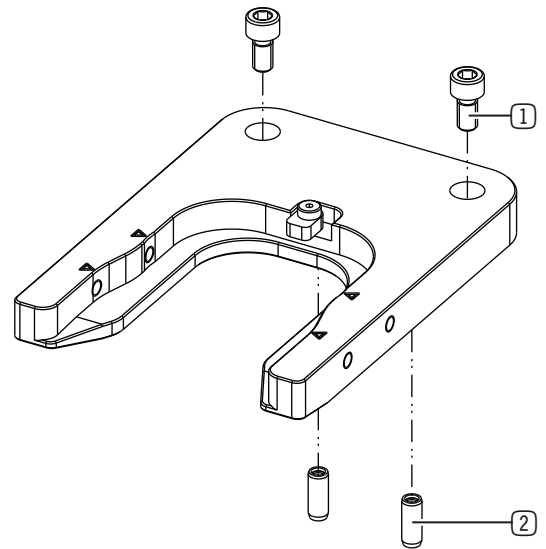

- ① Mounting screw
- ② Straight pins

10.2 Installing the stationary part on the robot

- ▶ Insert the straight pin into the designated fit on the stationary part.
- ▶ Position the stationary part on the robot.
- ▶ Loosely attach the mounting screws.
- ▶ Tighten the mounting screws without distortion.

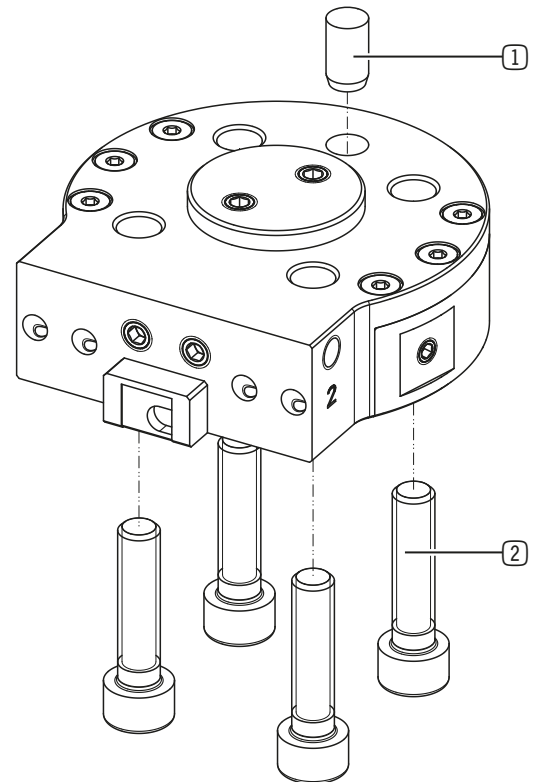

- ① Straight pins
- ② Mounting screw

10.3 Installing the tool to the loose part

The loose part can be installed from above or from below.

- ▶ Insert the straight pin into the designated fit on the loose part.
- ▶ Position the loose part on the tool.
- ▶ Loosely attach the mounting screws.
- ▶ Tighten the mounting screws without distortion.

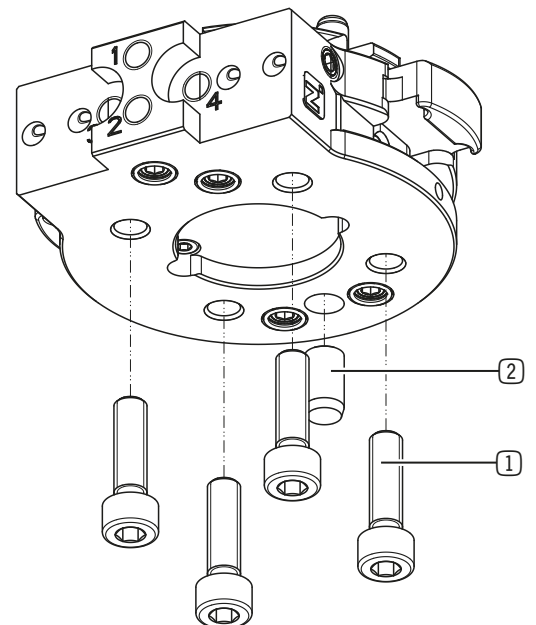
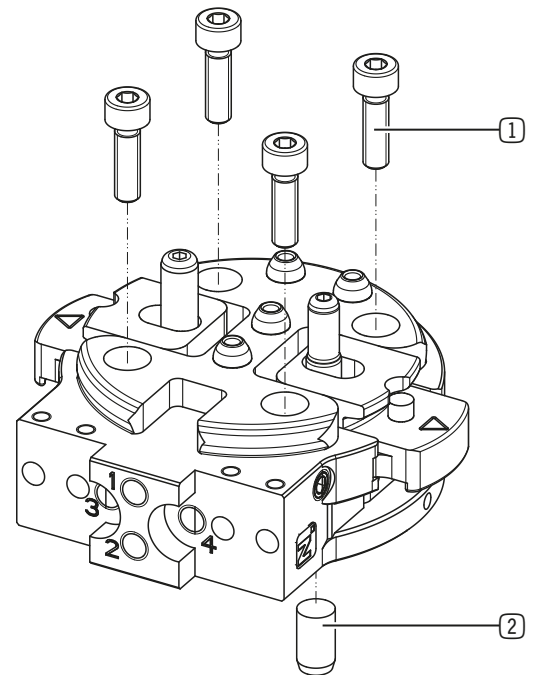

- ① Mounting screw
- ② Straight pins

10.4 Coupling the stationary part and loose part

WARNING



Suspended loads can cause injury

Falling loads can cause severe injuries.

- ▶ Always keep an adequate safety distance from suspended loads.
- ▶ Do not stand or walk underneath suspended loads.

Manual exchange:

The loose part can be installed on the stationary part and locked manually.

- ▶ Press the locking mechanism together.
- ▶ Position the loose part on the stationary part.
- ▶ Let go of the locking mechanism.

Automatic exchange:

Upon delivery, a lock is screwed on to both sides. This is the only way that the locking mechanism can be operated manually.

If a manual exchange is prohibited, the screw of the lock must be removed.

- ▶ Remove the screw.
- ⇒ The lock will rotate by 90°.

- ▶ Place the loose part above the marking in the storage station accordingly.
- ▶ Position the stationary part above the loose part.
- ▶ Lower the stationary part.
- ⇒ The loose part automatically locks with the stationary part during automatic extending out of the storage station.

- ① Screw
- ② Lock
- ③ Marking

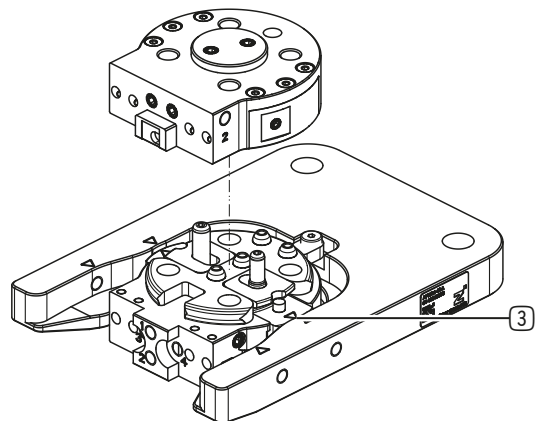
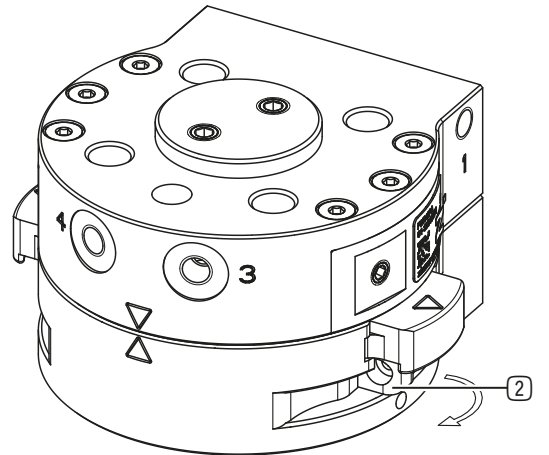
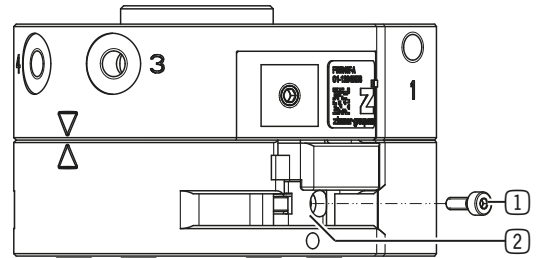
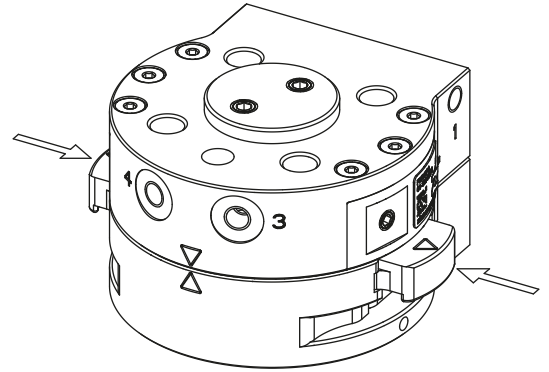

10.5 Installing the energy supply

INFORMATION



- ▶ You can find the information about connecting threads on the technical data sheet on our website.

- ▶ Mount the screw fittings in the provided connections.

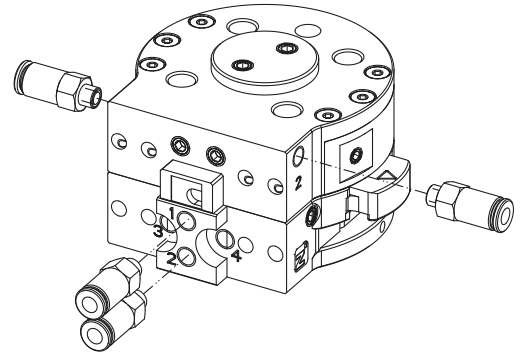

10.6 Installing the energy elements

NOTICE



Non-compliance may result in material damage.

- ▶ Before installing an accessory, make sure it is suitable for use with the selected variant.
- ▶ You can find information on our website.
- ▶ Please contact Customer Service if you have any questions.

- ▶ Install the energy element above the pin.

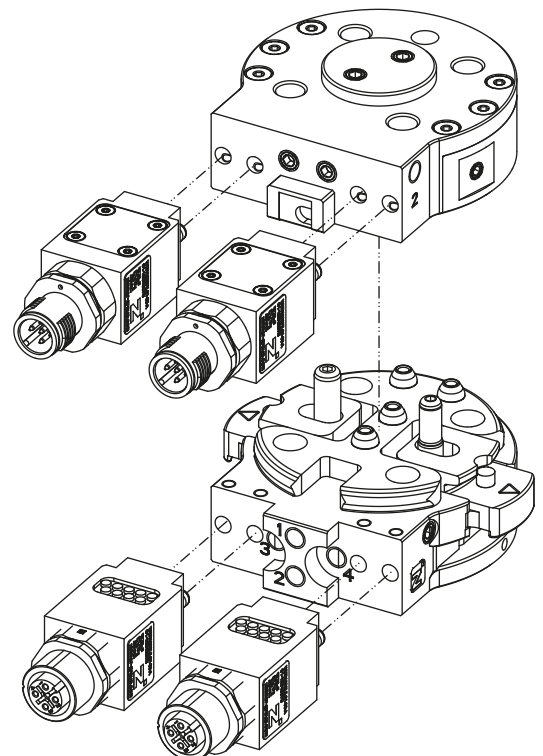

10.7 Installing the sensors

NOTICE



Non-compliance may result in material damage.

- ▶ Before installing an accessory, make sure it is suitable for use with the selected variant.
- ▶ You can find information on our website.
- ▶ Please contact Customer Service if you have any questions.

The sensors of the storage station check whether the loose part is present in the storage station and the locking is ensured. The sensor of the stationary part checks whether the loose part and stationary part are connected.

10.7.1 Installing the sensor on the stationary part

- ▶ Guide the cable through the opening in the cover.
- ▶ Fasten the sensor on the stationary part.
- ▶ Install the sensor on the stationary part with the countersunk screw.

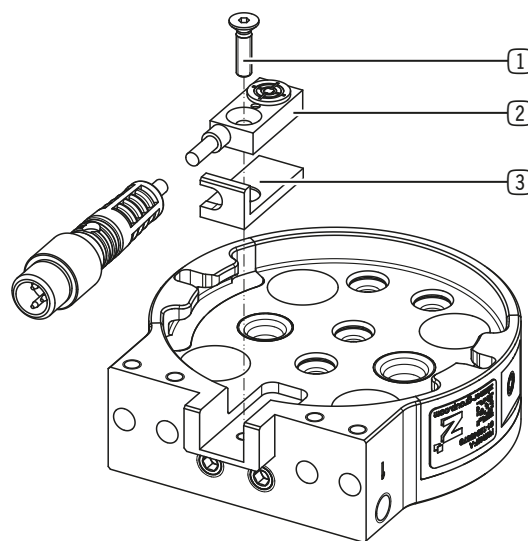

- ① Mounting screw
- ② Sensor
- ③ Cover

10.7.2 Installing the sensor on the storage station

- ▶ Install the sensors at the new storage station.

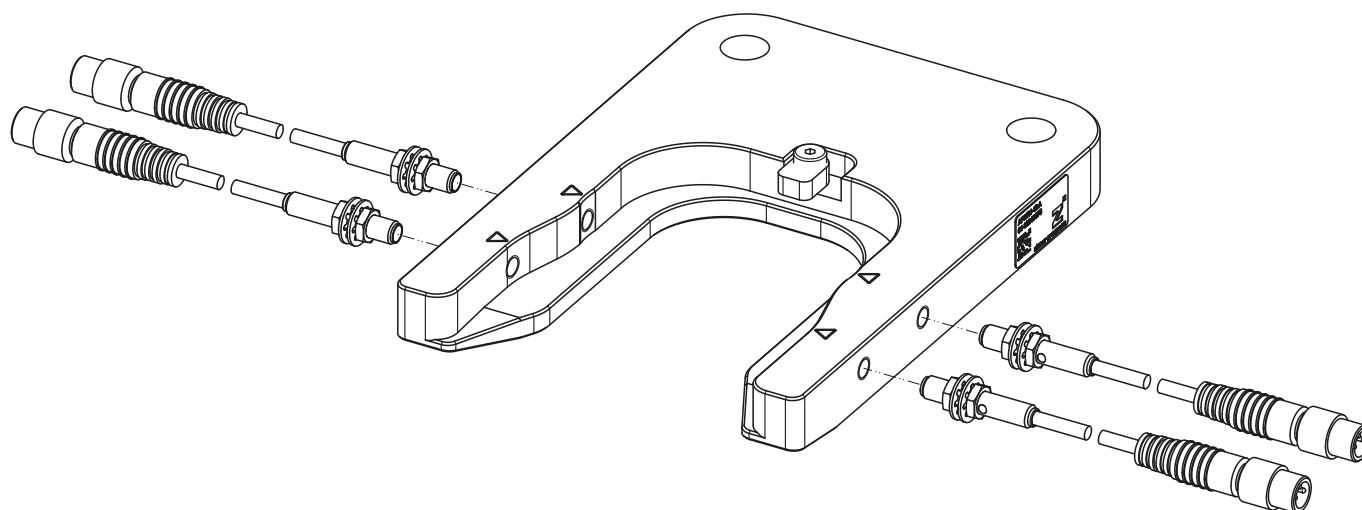

11 Commissioning

11.1 Setting up the storage station for the first time

- ▶ Unscrew the mounting screw of the end stop.
- ▶ Rotate the end stop 90°.
- ▶ Tighten the mounting screw.
- ▶ After commissioning, turn the end stop back again.

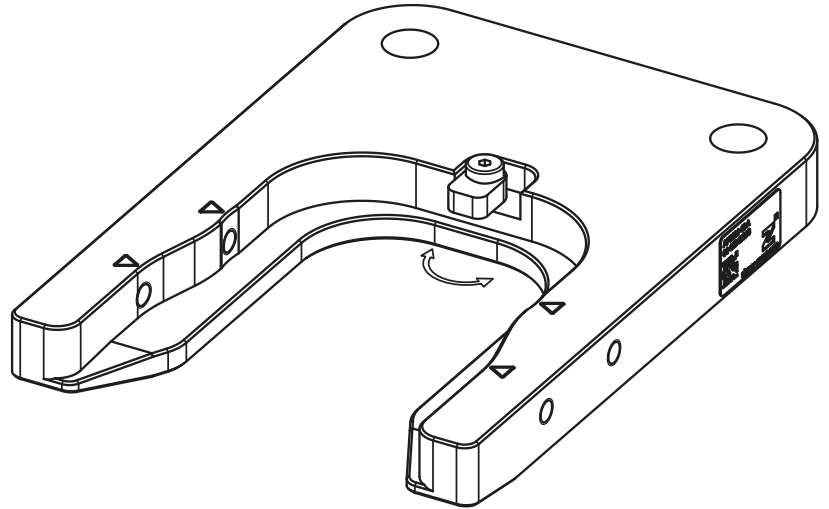

- ① Mounting screw
- ② Limit stop

11.2 Setting the sensors in the storage station

- ▶ Position the markings on the locking mechanism on the markings of the storage station.
- ▶ Turn in the sensors until they emit a signal.
- ▶ Fasten the sensors at this position.
- ▶ Coat the sensors with sealing lacquer.

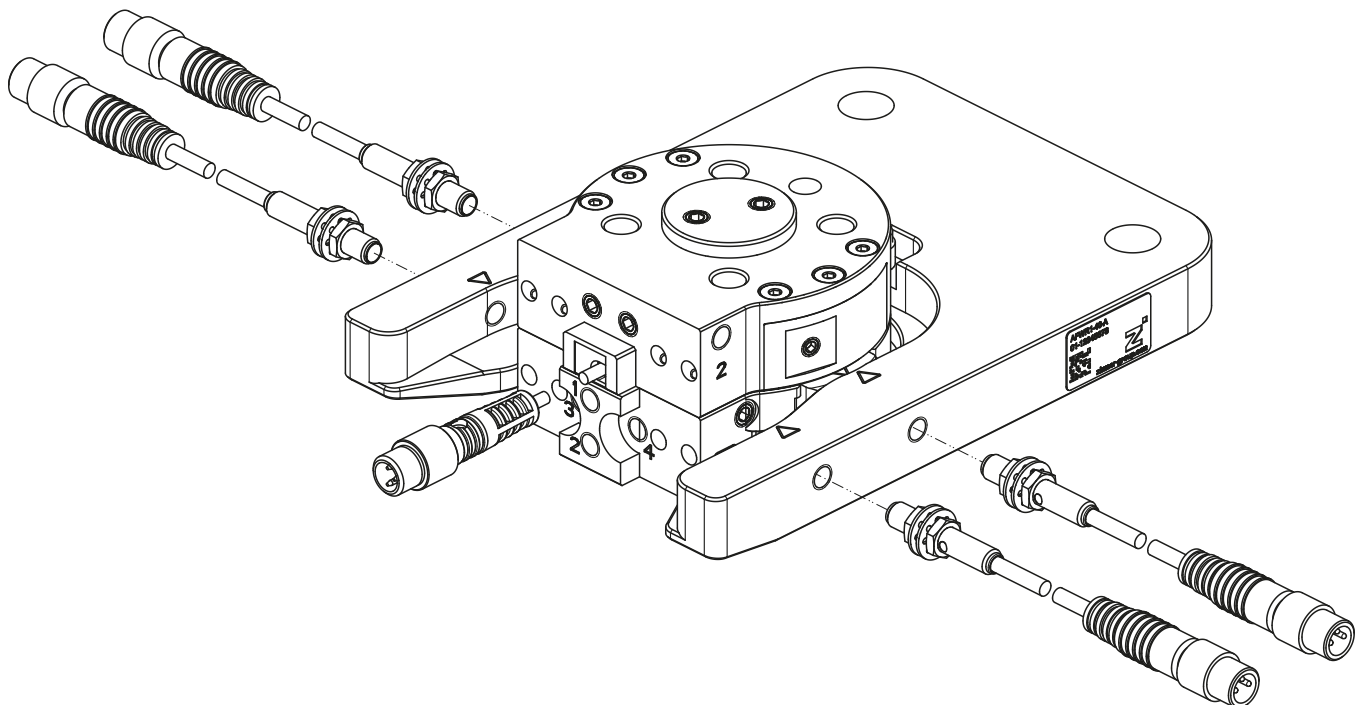

12 Maintenance

NOTICE

**Material damage resulting from blowing out with compressed air**

Blowing out the product with compressed air can cause malfunctions and pose a risk of accidents.

- ▶ Never purge the product with compressed air.

NOTICE

**Material damage caused by unsuitable cleaning materials**

Liquid and solvent-based cleaning agents can cause malfunctions and pose a risk of accidents.

- ▶ Do not clean the product with any cleaning agents that are liquid or contain solvents.

Operation of the product is maintenance-free.

- ▶ Note that the product could become damaged under the following circumstances:
 - Dirty environment
 - Improper use and use that does not comply with the performance data
 - Permissible temperature range not observed
- ▶ Even though the product is maintenance-free as mentioned above, perform a regular visual inspection to check for any damage or contamination.
- ▶ Have maintenance work that requires disassembly of the product performed by customer service only.
- ⇒ Dismantling and reassembling the product without authorization may result in complications, as special installation equipment is required in some cases. Zimmer GmbH accepts no liability for any resulting malfunctions or damage.

13 Decommissioning/disposal

INFORMATION



When the product reaches the end of its operational phase, it can be completely disassembled and disposed of.

- ▶ Disconnect the product completely from the power supply.
- ▶ Dispose of the components properly according to the material groups.
- ▶ Comply with the locally applicable environmental and disposal regulations.

14 REACH declaration

In terms of the EC Regulation 1907/2006

Name and address of the manufacturer:

Zimmer GmbH

 Im Salmenkopf
77866 Rheinau, Germany

 +49 7844 9138 0

 info@zimmer-group.com

 www.zimmer-group.com

REACH stands for **R**egistration, **E**valuation, **A**uthorisation and **R**estriction of **C**hemicals.

A full declaration of REACH can be obtained from the manufacturer due to the duty to notify in accordance with Art. 33 of the REACH regulation ("Duty to communicate information on substances in articles").

Michael Hoch

Authorized representative for the
compilation of relevant technical
documents

Rheinau, Germany, 2021-12-09

(Place and date of issuance)



Martin Zimmer
(Legally binding signature)
Managing Partner

15 Declaration of Incorporation

In terms of the EU Machinery Directive 2006/42/EC (Annex II 1 B)

Name and address of the manufacturer:

Zimmer GmbH

📍 Im Salmenkopf
77866 Rheinau, Germany
☎ +49 7844 9138 0
✉ info@zimmer-group.com
🌐 www.zimmer-group.com

We hereby declare that the incomplete machine described below

Product designation: Tool changer
Type designation: FWR

conforms to the requirements of the Machinery Directive, 2006/42/EC, Article 2g, Annex VII, b – Annex II, b, in its design and the version we put on the market.

Basic health and safety requirements:

No. 1.1.2, No. 1.1.3, No. .1.5, No. 1.3.2, No. 1.3.4, No. 1.3.7, No. 1.5.3, No. 1.5.4, No. 1.5.8, No. 1.6.4, No. 1.7.1, No. 1.7.4

A full list of applied standards can be obtained from the manufacturer.

We also declare that the specific technical documents were produced in accordance with Annex VII Part B of this Directive. We undertake to provide the market supervisory bodies with electronic versions of special documents for the incomplete machine through our documentation department, should they have reason to request them.

The incomplete machine may only be commissioned if it has been ascertained, if applicable, that the machine or system in which the incomplete machine is to be installed satisfies the requirements of Directive 2006/42/EC on Machinery and an EC Declaration of Conformity has been drawn up in accordance with Annex II 1 A.

Kurt Ross

Authorized representative for the compilation of relevant technical documents

Rheinau, Germany, 2021-12-09

(Place and date of issuance)



Martin Zimmer
(Legally binding signature)
Managing Partner